

たしざん(2)

ねん くみ
なまえ

19

■ つみきを見ながらたしざんをしましょう。

①

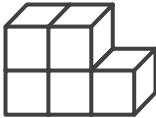
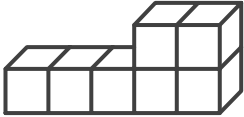
$$\begin{array}{r} 5 \\ + \\ 7 \\ \hline \end{array}$$

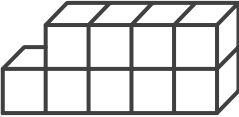

□

②

$$\begin{array}{r} 2 \\ + \\ 9 \\ \hline \end{array}$$

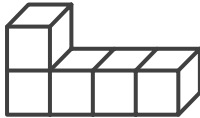
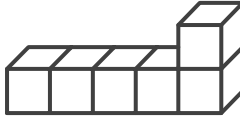

□

③

$$\begin{array}{r} 5 \\ + \\ 6 \\ \hline \end{array}$$

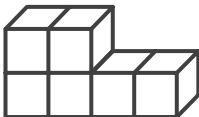
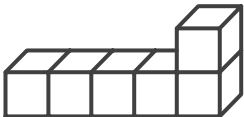

□

④

$$\begin{array}{r} 6 \\ + \\ 6 \\ \hline \end{array}$$

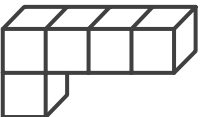
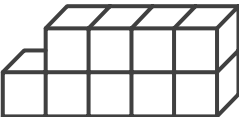

□

⑤

$$\begin{array}{r} 5 \\ + \\ 9 \\ \hline \end{array}$$

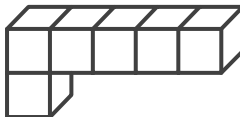
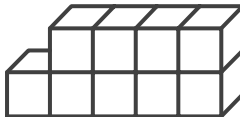

□

⑥

$$\begin{array}{r} 6 \\ + \\ 9 \\ \hline \end{array}$$

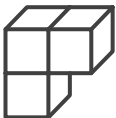
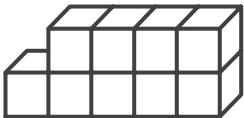

□

⑦

$$\begin{array}{r} 3 \\ + \\ 9 \\ \hline \end{array}$$

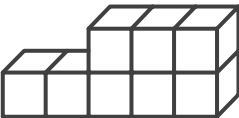

□

⑧

$$\begin{array}{r} 4 \\ + \\ 8 \\ \hline \end{array}$$

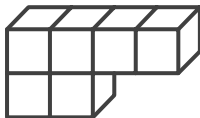
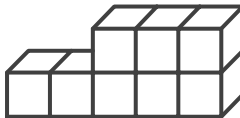

□

⑨

$$\begin{array}{r} 6 \\ + \\ 8 \\ \hline \end{array}$$



□

たしざん(2)

ねん くみ
なまえ

19

■ つみきを見ながらたしざんをしましょう。

①

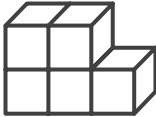
$$\begin{array}{r} 5 \\ + \\ 7 \\ \hline \end{array}$$

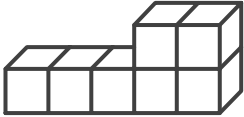

+



||

12

②

$$\begin{array}{r} 2 \\ + \\ 9 \\ \hline \end{array}$$

+

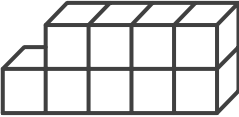

||

11

③

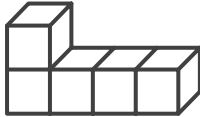
$$\begin{array}{r} 5 \\ + \\ 6 \\ \hline \end{array}$$

+

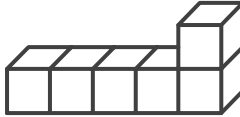

||

11

④

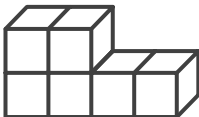
$$\begin{array}{r} 6 \\ + \\ 6 \\ \hline \end{array}$$

+

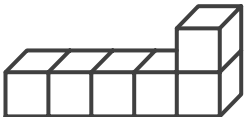

||

12

⑤

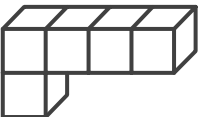
$$\begin{array}{r} 5 \\ + \\ 9 \\ \hline \end{array}$$

+

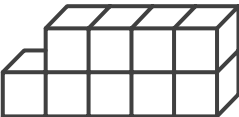

||

14

⑥

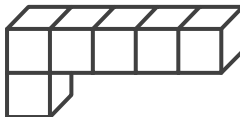
$$\begin{array}{r} 6 \\ + \\ 9 \\ \hline \end{array}$$

+

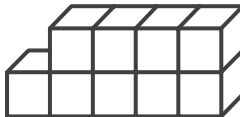

||

15

⑦

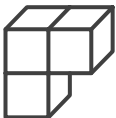
$$\begin{array}{r} 3 \\ + \\ 9 \\ \hline \end{array}$$

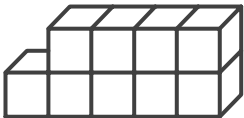

+



||

12

⑧

$$\begin{array}{r} 4 \\ + \\ 8 \\ \hline \end{array}$$

+

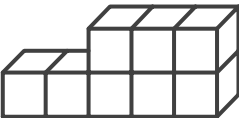

||

12

⑨

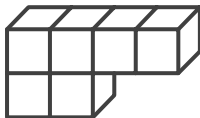
$$\begin{array}{r} 6 \\ + \\ 8 \\ \hline \end{array}$$

+

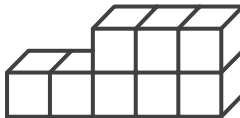

||

14